

Vencel Resil Limited

Infinity House
Anderson Way
Belvedere
Kent DA17 6BG

Tel: 020 8320 9100 Fax: 020 8320 9110
e-mail: technical@vencel.co.uk
website: www.jablite.co.uk



Agrément Certificate
00/3696
Product Sheet 1

JABROOF SLIMFIX SANDWICH ROOF ELEMENTS

PRODUCT SCOPE AND SUMMARY OF CERTIFICATE

This Certificate of Confirmation relates to Jabroof SlimFix Sandwich Roof Elements, used to provide insulation and structural support to slate or tile coverings in roofs with pitches between 15° and 70°, in domestic or commercial buildings.

AGRÉMENT CERTIFICATION INCLUDES:

- factors relating to compliance with Building Regulations where applicable
- factors relating to additional non-regulatory information where applicable
- independently verified technical specification
- assessment criteria and technical investigations
- design considerations
- installation guidance
- regular surveillance of production
- formal three-yearly review.

KEY FACTORS ASSESSED

Strength and stability — the elements have sufficient strength and stiffness to sustain the design loads (see section 5).

Thermal insulation — the elements can satisfy or contribute to satisfying the relevant thermal resistance requirements (see section 6).

Air leakage — the elements, when installed properly, can adequately limit air leakage (see section 7).

Condensation risk — the elements can adequately limit the risk of surface condensation and will contribute to minimising the risk of interstitial condensation (see section 8).

Behaviour in relation to fire — the elements have a Class 3 surface spread of flame rating without further protection (see section 9.2).

Weathertightness — the elements with a proper roof covering can provide adequate weathertightness (see section 10).

Durability — the elements will have adequate durability provided the roof covering is kept in good repair and they are not exposed to repeated condensation (see section 12).



The BBA has awarded this Agrément Certificate to the company named above for the products described herein. These products have been assessed by the BBA as fit for their intended use provided they are installed, used and maintained as set out in this Certificate.

On behalf of the British Board of Agrément

Brian Chamberlain
Head of Approvals — Engineering

Greg Cooper
Chief Executive

Date of First issue: 26 August 2008

Originally certificated on 28 March 2000

The BBA is a UKAS accredited certification body — Number 113. The schedule of the current scope of accreditation for product certification is available in pdf format via the UKAS link on the BBA website at www.bbacerts.co.uk

Readers are advised to check the validity and latest issue number of this Agrément Certificate by either referring to the BBA website or contacting the BBA direct.

British Board of Agrément
Bucknalls Lane
Garston, Watford
Herts WD25 9BA

©2008

tel: 01923 665300
fax: 01923 665301
e-mail: mail@bba.star.co.uk
website: www.bbacerts.co.uk

Regulations

In the opinion of the BBA, Jabroof SlimFix Sandwich Roof Elements, if used in accordance with the provisions of this Certificate, will meet or contribute to meeting the relevant requirements of the following Building Regulations:



The Building Regulations 2000 (as amended) (England and Wales)

Requirement:	A1	Loading
Comment:		The product has sufficient strength and stiffness to sustain the design loads in accordance with sections 5.1 to 5.4 of this Certificate.
Requirement:	B2	Internal fire spread (linings)
Comment:		The elements have a Class 3 surface spread of flame rating which restricts use to rooms with a floor area of not more than 4 m ² (residential accommodation) and not more than 30 m ² (non-residential building) in roof/ceiling situations without further protection. See section 9.2 of this Certificate.
Requirement:	C2(c)	Resistance to moisture
Comment:		The panels can adequately limit the risk of surface condensation and will contribute to minimising the risk of interstitial condensation. See sections 8.2 to 8.5 of this Certificate.
Requirement:	L1(a)(i)	Conservation of fuel and power
Comment:		See sections 6.1 to 6.4 and 7.1 and 7.2 of this Certificate.
Requirement:	Regulation 7	Materials and workmanship
Comment:		When used in accordance with the provisions of this Certificate this product is acceptable. The timber ribs are untreated and, therefore, are restricted under this Regulation. See sections 12.1 and 12.2 and the <i>Installation</i> part of this Certificate.



The Building (Scotland) Regulations 2004 (as amended)

Regulation:	8(1)(2)	Fitness and durability of materials and workmanship
Comment:		The product can contribute to a construction meeting this Regulation. See sections 11 and 12.1 and the <i>Installation</i> part of this Certificate.
Regulation:	9	Building standards – construction
Standard:	1.1(a)	Structure
Comment:		The product has sufficient strength and stiffness, with reference to clause 1.1.1 ⁽¹⁾⁽²⁾ , when designed in accordance with sections 5.1 to 5.4 of this Certificate.
Standard:	2.5	Internal linings
Comment:		The 'high risk' elements, in roof/ceiling situations without further protection, have a surface spread of flame rating which restricts use to rooms with a floor area of not more than 4 m ² (excluding kitchens in dwellings) and rooms with floor areas not more than 30 m ² that are non-domestic except room greater than 4 m ² in residential care buildings and hospitals, with reference to clause 2.5.1 ⁽¹⁾⁽²⁾ . See section 9.2 of this Certificate.
Standard:	3.15	Condensation
Comment:		For roofs in dwellings, the panels can adequately limit the risk of surface condensation and will contribute to minimising the risk of interstitial condensation, with reference to clauses 3.15.1 ⁽¹⁾ to 3.15.4 ⁽¹⁾ . See sections 8.2 to 8.5 of this Certificate.
Standard:	6.1(a)(b)	Carbon dioxide emissions
Standard:	6.2	Building insulation envelope
Comment:		The product can satisfy or contribute to satisfying these Standards, with reference to clauses 6.1.1 ⁽¹⁾ , 6.1.2 ⁽²⁾ , 6.1.3 ⁽²⁾ , 6.1.6 ⁽¹⁾ , 6.2.1 ⁽¹⁾⁽²⁾ , 6.2.3 ⁽¹⁾ , 6.2.4 ⁽¹⁾⁽²⁾ and 6.2.5 ⁽²⁾ . See sections 6.1 to 6.4, 7.1 and 7.3 of this Certificate. (1) Technical Handbook (Domestic). (2) Technical Handbook (Non-Domestic).



The Building Regulations (Northern Ireland) 2000 (as amended)

Regulation:	B2	Fitness of materials and workmanship
Comment:		The product is acceptable when used in accordance with the provisions of this Certificate. See section 12.1 and the <i>Installation</i> part of this Certificate.
Regulation:	B3(2)	Suitability of certain materials
Comment:		The product is acceptable. See section 11 of this Certificate.
Regulation:	C5	Condensation
Comment:		For roofs in dwellings, the panels will contribute to minimising the risk of interstitial condensation. See sections 8.3 to 8.5 of this Certificate.
Regulation:	D1	Stability
Comment:		The product has sufficient strength and stiffness to sustain the design loads in accordance with sections 5.1 to 5.4 of this Certificate.

Regulation:	E3	Internal fire spread — Linings
Comment:		The elements have a Class 3 surface spread of flame rating which restricts use to rooms with a floor area not more than 4 m ² (residential accommodation) and not more than 30 m ² (non-residential accommodation) in roof/ceiling situations without further protection. See section 9.2 of this Certificate.
Regulation:	F2(a)(i)	Conservation measures
Comment:		See sections 6.1 to 6.4, and 7.1 and 7.4 of this Certificate.

Construction (Design and Management) Regulations 2007

Construction (Design and Management) Regulations (Northern Ireland) 2007

Information in this Certificate may assist the client, CDM co-ordinator, designer and contractors to address their obligations under these Regulations.

See sections: 2 *Delivery and site handling* (2.1) and 13 *General* (13.1) (*Installation*).

Non-regulatory Information

NHBC Standards 2007

NHBC accepts the use of Jabroof SlimFix Sandwich Roof Elements, when installed and used in accordance with this Certificate, in relation to *NHBC Standards*, Chapter 7.2 *Pitched Roofs*.

Zurich Building Guarantee Technical Manual 2007

In the opinion of the BBA, Jabroof SlimFix Sandwich Roof Elements, when installed and used in accordance with this Certificate, satisfies the requirements of the *Zurich Building Guarantee Technical Manual*, Section *Superstructure*, Sub-section *Pitched roofs*.

General

This Certificate relates to Jabroof SlimFix Sandwich Roof Elements used to provide insulation and structural support to slate or tile coverings, in roofs with pitches between 15° and 70°, in domestic or commercial buildings.

The basic roof elements comprise an inner and outer particle board skin with an expanded polystyrene foam core.

The product is manufactured by IsoBouw Systems bv, Postbus 1, 5710 AA, Someren, Netherlands.

Tel: 00 31 493 4981111, Fax: 00 31 493 495971.

This Certificate is a Confirmation of Dutch Agrément No 20288/02 issued by KOMO⁽¹⁾ to IsoBouw Systems bv (the product is referred to as IsoBouw in the Dutch Agrément Certificate).

(1) Product certification system in the Netherlands.

Technical Specification

1 Description

1.1 Jabroof SlimFix Sandwich Roof Elements comprise panels of expanded polystyrene (EPS) foam (various thicknesses) bonded on internal and external faces with 8 mm thick particle board (see Table 1 and Figure 1). The external particle board has an orange paper and polyurethane film finish on the exposed face and the internal particle board a white finish on the exposed face. The element incorporates longitudinal timber ribs, gutter rail and counter battens (see Figure 2).

Table 1 Typical characteristics

Jabroof SlimFix element	Thickness of EPS insulation (mm)	Thickness of element ⁽¹⁾ (mm)	Weight (kgm ⁻²)
79 8/8	79	95	15
97 8/8	97	113	16
113 8/8	113	129	17
131 8/8	131	147	18
157 8/8	157	173	19
195 8/8	195	211	20

(1) Thickness excluding counter battens.

Figure 1 Section through element

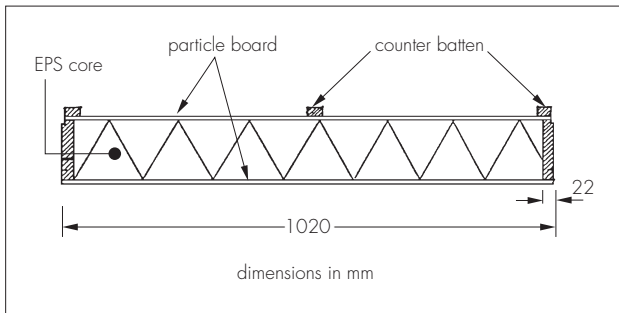
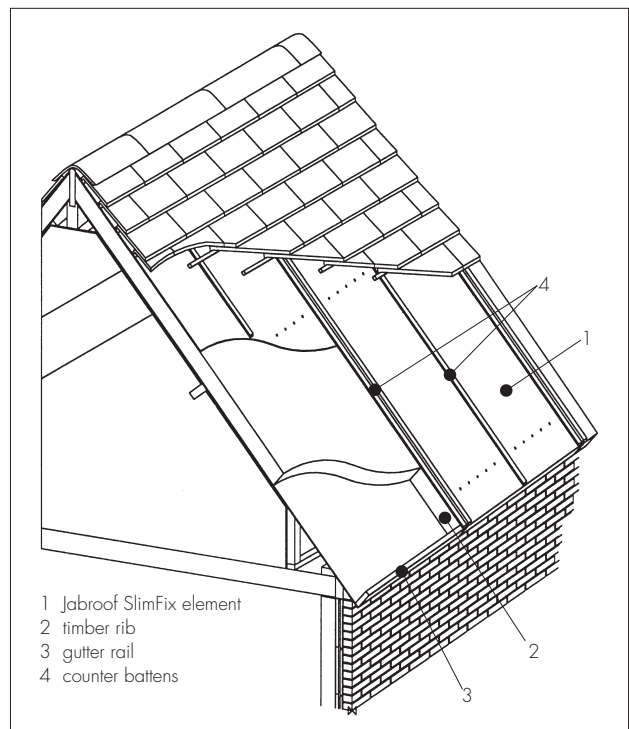

Figure 2 Typical construction detail



1.2 The elements are available in the sizes given in Table 2. Ridge-chamfered elements are available to special order.

1.3 Three timber counter battens (20 mm by 30 mm) are bonded to the external particle board surface (see Figure 1).

1.4 Various ancillary components⁽¹⁾ are available for use with the roofing system:

- fixings to suit the substrate — hooked nails, threaded/profiled nails, washer and hooks (length varying depending on panel thickness) of steel to BS EN 10230-1 : 2000 galvanized with a coating thickness of 5 µm (see Figure 3)
- self-adhesive, butyl/aluminium, foil tape⁽²⁾
- expanding polyurethane foam gap filler⁽²⁾.

(1) Not assessed by the BBA.

(2) Supplied with the product.

Table 2 Dimensions and tolerances

	Size (mm)	Tolerance in the nominal size
Length	variable up to 7520	1%
Width	1020	± 3 mm
Height (thickness of element) ⁽¹⁾	95 to 211	± 3 mm

(1) Excluding counter battens.

Figure 3 Fixings

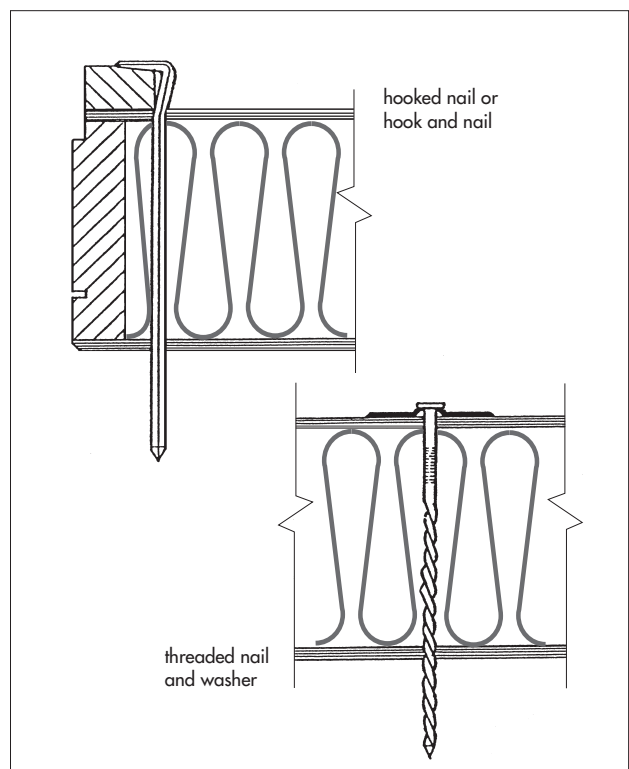

2 Delivery and site handling

2.1 The elements should be stored flat in an enclosed, dry building, and should be supported on timber bearers at 1.5 m centres (maximum) with the counter battens of the bottom element facing downward. Where temporary storage outside cannot be avoided, the stacks should be covered with polyethylene or tarpaulin sheet with the sides folded back to allow ventilation and be kept at least 150 mm clear of the ground.

2.2 The elements can withstand normal site handling and usage. Damaged elements which cannot be repaired easily must not be used.

Assessment and Technical Investigations

The following is a summary of the assessment and technical investigations carried out on Jabroof SlimFix Sandwich Roof Elements.

Design Considerations

3 General

3.1 Jabroof SlimFix Sandwich Roof Elements are satisfactory for use on buildings as an insulating, structural support for a conventional roofing of slate or tiles on roofs with a pitch of between 15° and 70° where access is limited to maintenance and repair. The pitch should be determined by the type of tiles/slates used.

3.2 The selection of the elements⁽¹⁾ and roof design must be carried out by, or under direct supervision of, chartered structural or civil engineers, or other suitably qualified persons, in accordance with UK building practice and Building Regulations.

(1) Based on the load limitations given in sections 5.2 to 5.4.

4 Practicability of installation

The elements are practicable to install using the methods described in this Certificate and the manufacturer's recommended fixing instructions.

5 Strength and stability



5.1 The elements will have adequate strength and stiffness to sustain specified loads when used in accordance with the provisions of this Certificate.

5.2 The permissible span for a range of loading conditions is given in Tables 3 to 8 and is based on the requirements of BS EN 1995-1.1 : 2004, the UK National Application Document and the criteria summarised below, specifically items (4), (5) and (6). For loading conditions outside of these criteria (ie tile weights greater than 42 kgm⁻²), the Certificate holder's advice should be sought:

(1) span refers to the maximum length along the roof slope.

(2) the data are based on compliance with the wind loading defined in NEN 6702 : 1991⁽¹⁾. The checks include:

- strength and rigidity of the roof construction in accordance with SKH publication 94-2
- deflection under service limited to span/200
- bending stresses in the timber.

(1) The pressure coefficients (see Table 9) used to determine the external and internal surface wind pressures differ slightly from those given in BS 6399-2 : 1997 but are considered reasonable for most situations.

(3) it is assumed in the design that local buckling is prevented by the full support given by the expanded polystyrene

(4) in the calculation, it is assumed that roof tiles have a dead load of less than 42 kgm⁻²

(5) allowance is not made for battens or plasterboard

(6) wind pressure coefficients and snow loads used in the calculation are given in Table 9.

Table 3 Spans⁽¹⁾⁽²⁾ — Jabroof SlimFix 79 8/8

Roof slope	Span (mm)					
	Dynamic wind pressure (q _s) 1210 Nm ⁻²			Dynamic wind pressure (q _s) 1530 Nm ⁻²		
	Single span	Two spans	Three spans	Single span	Two spans	Three spans
15°	2000	2250	2187	1719	1800	1899
20°	2270	2550	2427	1899	2040	2049
25°	2390	2610	2652	2139	2160	2302
30°	2540	2345	2682	2349	2158	2452
35°	2600	2465	2802	2379	2248	2572
40°	2630	2525	2862	2439	2308	2632
45°	2690	2514	2850	2499	2280	2603
50°	2670	2461	2748	2400	2227	2497
55°	2617	2355	2708	2301	2121	2391
60°	2511	2249	2602	2249	2015	2285
65°	2405	2143	2496	2090	1909	2179
70°	2379	2140	2440	2079	1900	2140

- (1) Maximum distance between centres of the support purlins.
 (2) See section 5.2.

Table 4 Spans⁽¹⁾⁽²⁾ — Jabroof SlimFix 97 8/8

Roof slope	Span (mm)					
	Dynamic wind pressure (q _s) 1210 Nm ⁻²			Dynamic wind pressure (q _s) 1530 Nm ⁻²		
	Single span	Two spans	Three spans	Single span	Two spans	Three spans
15°	2200	2637	2485	1963	2130	2167
20°	2740	2907	2725	2173	2370	2317
25°	2860	2937	3081	2413	2490	2628
30°	2890	2695	3043	2623	2458	2748
35°	3040	2785	3163	2743	2548	2868
40°	3070	2845	3223	2773	2608	2988
45°	3100	2830	3253	2803	2580	2944
50°	2972	2788	3117	2726	2474	2838
55°	2919	2629	3067	2620	2368	2732
60°	2813	2579	2908	2514	2315	2573
65°	2707	2420	2749	2408	2156	2467
70°	2619	2440	2770	2319	2140	2439

- (1) Maximum distance between centres of the support purlins.
 (2) See section 5.2.

Table 5 Spans⁽¹⁾⁽²⁾ — Jabroof SlimFix 113 8/8

Roof slope	Span (mm)					
	Dynamic wind pressure (q _s) 1210 Nm ⁻²			Dynamic wind pressure (q _s) 1530 Nm ⁻²		
	Single span	Two spans	Three spans	Single span	Two spans	Three spans
15°	2400	2871	2711	2245	2394	2340
20°	3082	3219	2981	2455	2664	2550
25°	3202	3249	3418	2695	2784	2878
30°	3163	2901	3365	2905	2678	3058
35°	3253	3051	3485	3025	2798	3178
40°	3343	3141	3575	3085	2888	3268
45°	3320	3111	3545	3054	2852	3226
50°	3267	3058	3439	2948	2746	3120
55°	3161	2899	3333	2842	2640	3014
60°	3055	2846	3227	2736	2481	2908
65°	2949	2687	3068	2577	2375	2696
70°	2859	2680	3040	2559	2350	2680

- (1) Maximum distance between centres of the support purlins.
 (2) See section 5.2.

Table 6 Spans⁽¹⁾⁽²⁾ — Jabroof SlimFix 131 8/8

Roof slope	Span (mm)					
	Dynamic wind pressure (q _s) 1210 Nm ⁻²			Dynamic wind pressure (q _s) 1530 Nm ⁻²		
	Single span	Two spans	Three spans	Single span	Two spans	Three spans
15°	2650	3165	3021	2487	2688	2597
20°	3513	3495	3291	2757	2928	2807
25°	3603	3525	3752	3027	3048	3175
30°	3444	3230	3699	3147	2942	3355
35°	3564	3350	3819	3297	3092	3475
40°	3654	3440	3909	3387	3152	3595
45°	3625	3411	3892	3334	3121	3547
50°	3572	3358	3786	3228	3015	3441
55°	3413	3199	3680	3122	2909	3335
60°	3307	3093	3574	2963	2750	3190
65°	3148	2934	3362	2857	2644	3010
70°	3159	2950	3340	2799	2590	2979

- (1) Maximum distance between centres of the support purlins.
 (2) See section 5.2.

Table 7 Spans⁽¹⁾⁽²⁾ — Jabroof SlimFix 157 8/8

Roof slope	Span (mm)					
	Dynamic wind pressure (q _s) 1210 Nm ⁻²			Dynamic wind pressure (q _s) 1530 Nm ⁻²		
	Single span	Two spans	Three spans	Single span	Two spans	Three spans
15°	3010	3604	3403	2970	3021	2979
20°	4086	3964	3733	3270	3321	3189
25°	4206	4024	4221	3510	3471	3603
30°	3835	3653	4168	3540	3365	3783
35°	3985	3773	4288	3690	3485	3963
40°	4075	3893	4408	3780	3575	4053
45°	4046	3854	4362	3727	3533	4000
50°	3993	3748	4256	3621	3427	3894
55°	3834	3642	4150	3515	3268	3735
60°	3728	3536	3991	3356	3109	3576
65°	3569	3324	3779	3197	3003	3354
70°	3519	3340	3760	3159	2950	3340

- (1) Maximum distance between centres of the support purlins.
 (2) See section 5.2.

Table 8 Spans⁽¹⁾⁽²⁾ — Jabroof SlimFix 195 8/8

Roof slope	Span (mm)					
	Dynamic wind pressure (q _s) 1210 Nm ⁻²			Dynamic wind pressure (q _s) 1530 Nm ⁻²		
	Single span	Two spans	Three spans	Single span	Two spans	Three spans
15°	3990	3850	4120	3090	3280	3520
20°	4530	4240	4480	3510	3580	3850
25°	4830	4570	5050	3930	3850	4300
30°	4470	4360	4900	4170	4000	4530
35°	4710	4540	5130	4350	4180	4720
40°	4830	4660	5260	4470	4300	4840
45°	4710	4600	5190	4350	4210	4750
50°	4650	4480	5070	4230	4060	4590
55°	4470	4360	4900	4110	3940	4420
60°	4350	4210	4750	3930	3760	4270
65°	4170	4000	4530	3750	3580	4050
70°	4110	3940	4460	3630	3520	3970

- (1) Maximum distance between centres of the support purlins.
 (2) See section 5.2.

5.3 Wind loads must be evaluated in accordance with BS 6399-2 : 1997. The spans given in Tables 3 to 8 are based on wind pressures of 1210 Nm⁻² and 1530 Nm⁻² which cover the range of pressures likely to occur in the UK and the pressure coefficients given in Table 9 (see also Figure 4).

Table 9 Wind pressure coefficients and snow loads used in the calculation to determine spans in Tables 3 to 8

Roof slope	External pressure coefficients ⁽¹⁾			Internal pressure coefficients ⁽¹⁾		Snow load (Nm ⁻²)	
	C _{pe1}	C _{pe2}	C _{pe3}	C _{pi1}	C _{pi2}	q _s =1210 (Nm ⁻²)	q _s =1530 (Nm ⁻²)
15°	-0.90	-1.75	-0.95	-0.3	+0.2	640	800
20°	-0.70	-1.50	-0.80	-0.3	+0.2	750	930
25°	-0.45	-1.25	-0.80	-0.3	+0.2	850	1070
30°	-0.20	-1.00	-0.80	-0.3	+0.2	960	1200
35°	-0.07	-0.93	-0.80	-0.3	+0.2	800	1000
40°	+0.07	-0.87	-0.80	-0.3	+0.2	640	800
45°	+0.20	-0.80	-0.80	-0.3	+0.2	480	600
50°	+0.33	-0.80	-0.80	-0.3	+0.2	320	400
55°	+0.47	-0.80	-0.80	-0.3	+0.2	160	200
60°	+0.60	-0.80	-0.80	-0.3	+0.2	0	0
65°	+0.73	-0.80	-0.80	-0.3	+0.2	0	0
70°	+0.80	-0.80	-0.80	-0.3	+0.2	0	0

(1) See Figure 4.

Figure 4 Arrangement of wind-pressure coefficients

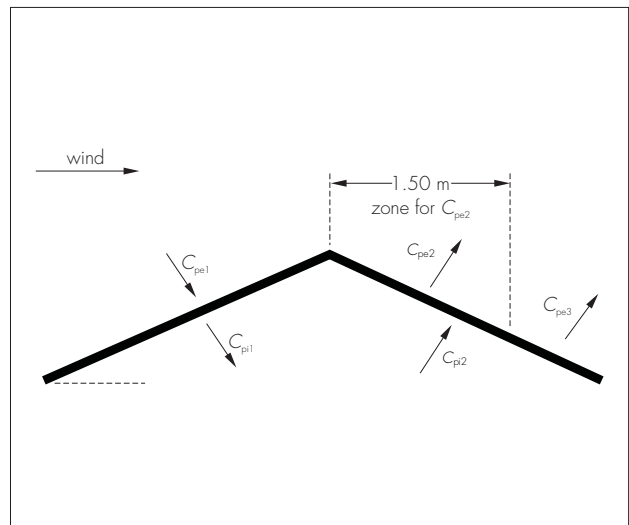

5.4 Imposed snow loads must be checked in accordance with the recommendations of BS 6399-3 : 1988. The basic snow load used in the calculation is given in Table 9.

5.5 The number of fixings required to secure the panels to the roof structure will depend upon various factors, such as the site location, geometry of the roof and type of roof structure. Therefore, it is recommended that the fixings are calculated for each site using the provisions of BS 5268-2 : 2002. The specifications and design calculations must be determined by the engineer responsible for the stability of the building⁽¹⁾.

(1) Strength data for the hooked and threaded nails can be supplied by the Certificate holder.

5.6 In general, each element is secured at the wall plate, purlin(s) and ridge by a minimum of three hooked or threaded nails at each counter batten, up to a pitch of 60°, and four nails for steeper pitches. Additional nails are required at the wall plate where the element length exceeds 3600 mm depending on the pitch of the roof (see Table 10), but must be confirmed by the engineer responsible for the roof design.

Table 10 Number of additional nails per element

Roof pitch	Element length (maximum) (mm)				
	3600	4800	5400	6000	7200
15° to 45°	0	2	3	3	5
45° to 70°	1	3	3	4	6

5.7 Except where otherwise stated in this Certificate, the fixing of components including tiling/gutter laths, slates and tiles, should be carried out in accordance with BS 5534 : 2003.

5.8 All transverse joints between the roof elements must be supported.

5.9 Gutters should be fixed to avoid water overshoot.

6 Thermal insulation



6.1 The thermal performance of each building incorporating the panels must be evaluated in accordance with the relevant national Building Regulations, and is the responsibility of the overall designer of the building.

6.2 Calculations⁽¹⁾ of the thermal transmittance of specific constructions should be based on thermal conductivity values (Wm⁻¹K⁻¹) of:

expanded polystyrene insulation core	0.03 ⁽²⁾
particle board	0.15
timber	0.15

(1) Calculations should be carried out in accordance with BS EN ISO 6946 : 1997 and BRE report (BR443 : 2006) *Conventions for U-value calculations* taking into consideration the thermal bridging effect of metal fixings used.

(2) Manufacturer's declared $\lambda_{90/90}$ value.

6.3 Typical U values for roofs, lined internally with 12.5 mm plasterboard and externally slated or tiled, calculated in accordance with BS EN ISO 6946 : 1997 and BRE report (BR 443 : 2006), are given in Table 11.

Table 11 Thermal resistances of roof elements and U values of roof

Insulation thickness (mm)	Thermal resistance of roof elements (m^2KW^{-1})	Maximum U value of roof ⁽¹⁾ ($\text{Wm}^{-2}\text{K}^{-1}$)
79	2.36	0.37
97	2.88	0.31
113	3.33	0.27
131	3.84	0.24
157	4.58	0.20
195	5.66	0.16 ⁽²⁾

(1) Calculated without accounting for the effect of thermal bridging caused by the use of metal fixings.

(2) It is assumed that there is an internal batten void between the roof element and the plasterboard.

6.4 Constructions incorporating the appropriate panel thickness can meet the requirements of the national Building Regulations:

England and Wales

- 0.16⁽¹⁾ $\text{Wm}^{-2}\text{K}^{-1}$ for a 'notional' dwelling in SAP 2005
- 0.25⁽¹⁾ $\text{Wm}^{-2}\text{K}^{-1}$ for a 'notional' building, other than a dwelling, in SBEM
- 0.25 $\text{Wm}^{-2}\text{K}^{-1}$ limit average U value for a roof in Approved Documents L1A and L2A
- 0.35 $\text{Wm}^{-2}\text{K}^{-1}$ limit U value for an individual roof element in Approved Documents L1A and L2A
- the junction shown in Figure 8 adequately limits heat loss by conduction and, when installed to limit air infiltration (see sections 7.1 and 7.2), complies with the requirements of *Limiting thermal bridging and air leakage: Robust construction details for dwellings and similar buildings* TSO 2002, and the Accredited Construction Details (version 1.0). The default psi value quoted in BRE Information Paper IP 1/06 *Assessing the effects of thermal bridging at junctions and around openings*, Table 3, therefore, may be used in SAP or SBEM calculations.

(1) Where a proposed building roof U value is not better than the 'notional' value specified above, additional energy saving measures will be required within the building envelope and/or services, to achieve the required overall carbon dioxide emission rate reduction of about 20% for dwellings and between 23% and 28% for buildings other than dwellings.

Scotland

- U value of 0.16 $\text{Wm}^{-2}\text{K}^{-1}$ specified for:
 - a 'notional' domestic roof with reference to Mandatory Standard 6.1, clause 6.1.2⁽¹⁾, and SAP 2005
 - a 'notional' non-domestic pitched roof ($>10^\circ$) with reference to Mandatory Standard 6.1, clause 6.1.3⁽²⁾, and when 'Scotland' is selected in SBEM
- 0.20 $\text{Wm}^{-2}\text{K}^{-1}$ maximum average value specified in Table to Mandatory Standard 6.2, clause 6.2.1⁽¹⁾
- 0.25 $\text{Wm}^{-2}\text{K}^{-1}$ maximum average value specified in Table to Mandatory Standard 6.2, clause 6.2.1⁽²⁾
- 0.35 $\text{Wm}^{-2}\text{K}^{-1}$ maximum value for an individual roof element specified in Table to Mandatory Standard 6.2, clause 6.2.1⁽¹⁾⁽²⁾.

(1) Technical Handbook (Domestic).

(2) Technical Handbook (Non-Domestic).

Northern Ireland

- 0.16⁽¹⁾ $\text{Wm}^{-2}\text{K}^{-1}$ for a 'notional' dwelling in SAP 2005
- 0.25⁽¹⁾ $\text{Wm}^{-2}\text{K}^{-1}$ for a 'notional' building, other than a dwelling, in SBEM
- 0.25 $\text{Wm}^{-2}\text{K}^{-1}$ limit average U value for a roof in Technical Booklets F1 and F2
- 0.35 $\text{Wm}^{-2}\text{K}^{-1}$ limit U value for an individual roof element in Technical Booklets F1 and F2
- the junction shown in Figure 8 adequately limits heat loss by conduction and, when installed to limit air infiltration (see sections 7.1 and 7.2), complies with the requirements of the Accredited Construction Details (version 1.0). The default psi value quoted in BRE Information Paper IP 1/06, Table 3, therefore, may be used in SAP or SBEM calculations.

(1) Where a proposed building roof U value is not better than the 'notional' value specified above, additional energy saving measures will be required within the building envelope and/or services, to achieve the required overall carbon dioxide emission rate reduction of about 20% for dwellings and between 23% and 28% for buildings other than dwellings.

7 Air leakage



7.1 To minimise air leakage, the panels must be installed and sealed in accordance with the Certificate holder's recommendations at all joints, junctions and any penetrations.



7.2 Completed buildings in England and Wales are subject to pre-completion testing for airtightness in accordance with the requirements of Approved Documents L1A and L2A, Section 20B.

 7.3 Completed buildings in Scotland are subject to pre-completion testing for airtightness if the target air permeability of the proposed building is less than $10 \text{ m}^3\text{h}^{-1}\text{m}^{-2}$, or if the figure is between $10 \text{ m}^3\text{h}^{-1}\text{m}^{-2}$ and $15 \text{ m}^3\text{h}^{-1}\text{m}^{-2}$ default figure in the proposed building, in accordance with Mandatory Standard 6.2, clauses 6.2.5⁽¹⁾ and 6.2.6⁽²⁾.

(1) Technical Handbook (Domestic).

(2) Technical Handbook (Non-Domestic).

 7.4 In Northern Ireland, completed buildings are subjected to pre-completion testing for airtightness in accordance with the requirements of Technical Booklet F1, Sections 2.46 to 2.54, and Technical Booklet F2, Sections 2.57 to 2.61.

8 Condensation risk

8.1 The risk of interstitial condensation is greatest when the building is drying out after construction. Guidance on preventing condensation from this and other sources is given in BRE Digest 369 *Interstitial condensation and fabric degradation* and BRE Report (BR 262) *Thermal insulation : Avoiding risks*.

Surface condensation

 8.2 The risk of surface condensation in roofs and at junctions shown in Figures 5 and 8 will be minimal.

Interstitial condensation

 8.3 The risk of interstitial condensation will be minimal when the panels are used in conjunction with a vapour check plasterboard lining, or other suitably installed vapour control layer. However, it is essential that care is taken to minimise the risk of vapour penetrating to cold parts of the construction. All joints must be sealed in accordance with the Certificate holder's instructions and section 14 (see also section 11).

8.4 Type LR Roof tile underlays should be installed in accordance with the relevant instructions.

8.5 For the purposes of calculation, the vapour resistance and resistivity values may be taken as:

24 MNsg^{-1}	white finish to internal surface of panel
5 MNsg^{-1}	particle board
145 MNsg^{-1}	expanded polystyrene
14 MNsg^{-1}	orange finish of the outer surface panel.

9 Behaviour in relation to fire

9.1 Tests to BS 476-3 : 1958 have shown that, when installed below concrete or clay tiles or slates, a roof incorporating Jabroof SlimFix elements would achieve an EXT.S.AA designation.

 9.2 The particle board surface of the elements can be regarded as having a Class 3 surface spread of flame ('high risk' in Scotland). Once installed, all of the product range present a particle board surface to the occupied space. Hence, compliance with the Building Regulations limits its use to rooms with a floor area of 4 m^2 [residential accommodation (other than kitchens in Scotland)] and 30 m^2 (non-residential accommodation except rooms greater than 4 m^2 in residential care buildings and hospitals in Scotland) in roof/ceiling situations without additional protection. Therefore, for most practical purposes, an additional lining of 12.5 mm thick plasterboard, or similar, with a Class 1 surface spread of flame rating will be required to satisfy the Regulations.

9.3 Where other forms of construction are used, an appropriate assessment or test must be undertaken. Testing must be carried out by a UKAS approved fire testing laboratory.

10 Weathertightness

10.1 The long-term weathertightness of a roof constructed using Jabroof SlimFix Sandwich Roof Elements will depend upon the quality and use of an interlocking slating and tiling system.

10.2 It is important to ensure that the joints between the elements are adequately sealed.

11 Maintenance

 Maintenance of the elements will not be required provided the weathertightness of the slating or tiling system is kept in good repair.

12 Durability

 12.1 The elements will have a durability comparable to that of particle board types P5 and P7 in accordance with BS EN 312 : 2003. Therefore, they will have adequate durability provided they are not exposed to repeated condensation and the roof covering is kept in good repair. To ensure these conditions are maintained, the roof covering must be in accordance with the requirements of BS 5534 : 2003. The underside of the elements must be protected against dampness at eaves and gable projections by such measures as painting, boarding or panelling.



12.2 The timber ribs are not preservative treated and, therefore, are not suitable for use in roof spaces in the House Longhorn beetle (*Hylotrupes bajulus L*) areas defined in the Approved Document to Regulation 7 of the Building Regulations (England and Wales).

Installation

13 General

13.1 Jabroof SlimFix Sandwich Roof Elements should be fitted by roof contractors or carpenters. Where hoisted by crane, webbing slings or cradle should be used, attached to the element in the designated lifting zone. The company's technical literature contains recommendations for the installation of the roof elements. Typical details are shown in Figures 5 to 8.

13.2 The fixings used in the installation will depend upon the type of element framework and roof pitch. Fixings are supplied with the elements and details can be found in Jabroof SlimFix fixing instructions. The number and centres for these fixings are found by calculation (see sections 5.5 and 5.6).

13.3 Each roof element must have a minimum bearing of 30 mm at each support, with intermediate supports at least 59 mm wide. When laying onto steelwork or masonry material, a strip of compressible material (eg 2 mm roofing felt) should be fitted under the roof element.

13.4 The elements may be cut on site using a power saw. The minimum width of a sawn panel is 300 mm. The sawn edge of the panel should be laid near the gable wall, and supported by a 38 mm by 50 mm timber rib.

Figure 5 Ridge detail

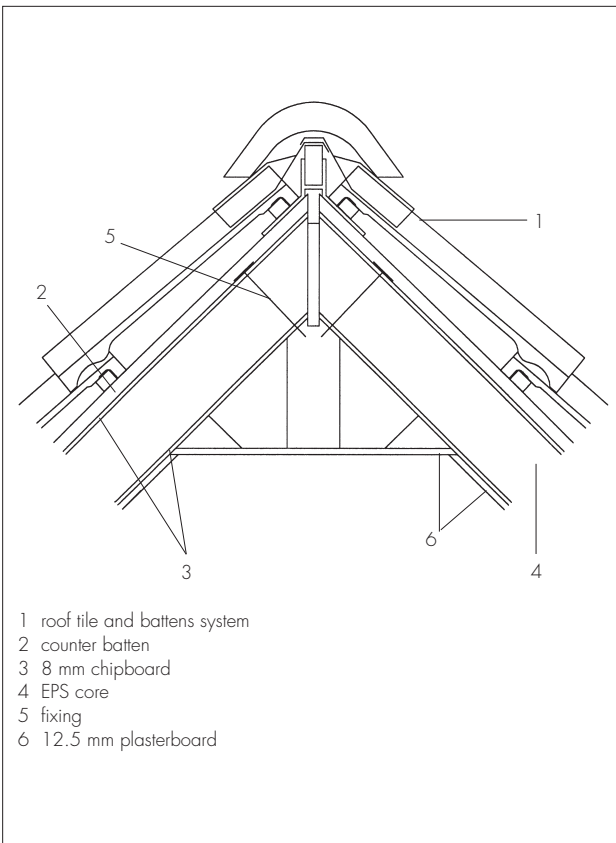

Figure 7 Intermediate purlin detail

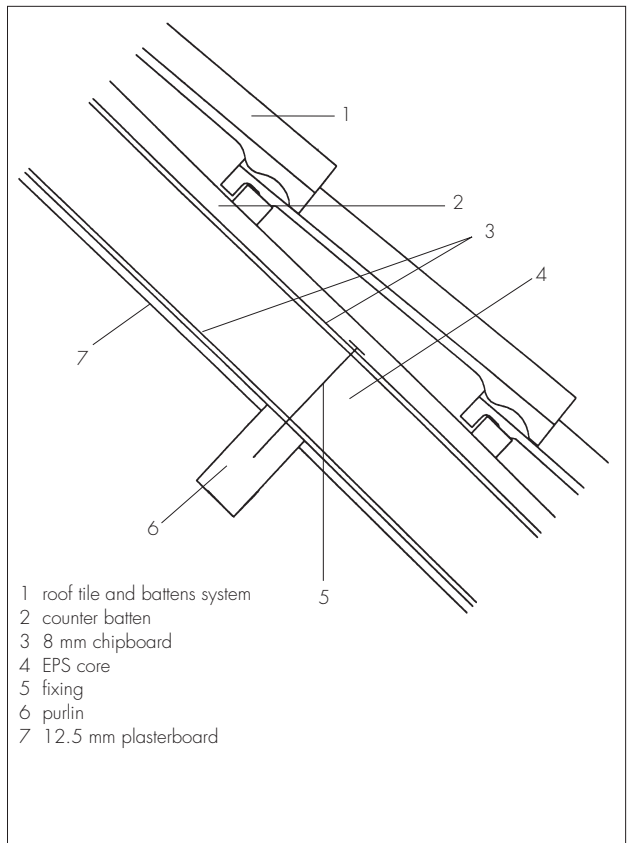

Figure 6 Structural support detail

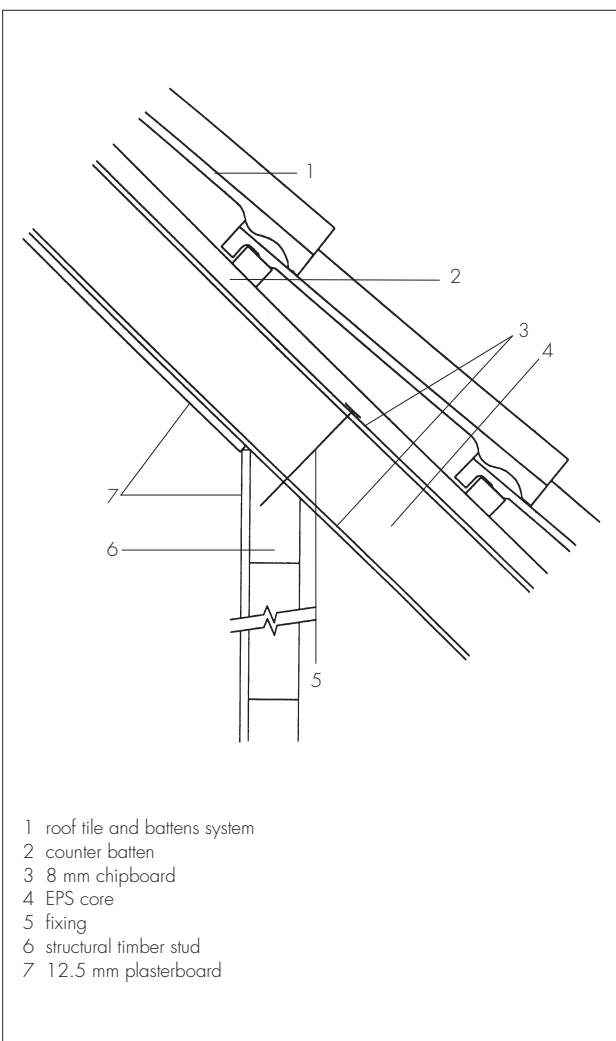
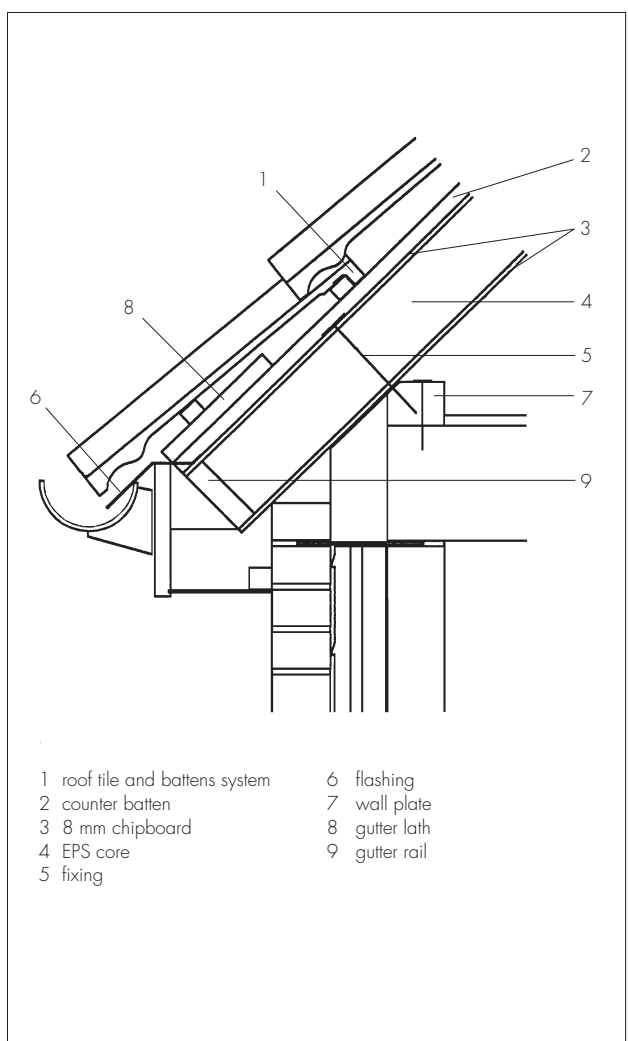

Figure 8 Wall plate eaves detail



13.5 Gable ends can overhang by a maximum of 150 mm without additional support.

13.6 At openings, eg rooflights, trimming is not required provided they fall within the longitudinal timber rib of one element.

13.7 A collar should be fitted to a chimney or flue penetrating an element to prevent temperatures exceeding 90°C.

14 Procedure

14.1 The first element is secured at each purlin or rafter position and to the wall plate by the appropriate number and type of fixing.

14.2 The next element is butted against the first and fastened to the purlins, rafters or wall plate with the appropriate fasteners. Subsequent elements are fastened to complete the roof.

14.3 The last element should be trimmed lengthways and secured. If necessary, elements can be butt jointed end to end over a support.

14.4 When the installation is complete the joints should be sealed. Vertical joints are sealed on the top surface using expanding polyurethane (PUR) foam. Excess amounts of PUR must be trimmed (see Figure 9). Horizontal joints between elements are filled with PUR foam, trimmed and sealed with foil tape.

Figure 9 Detail of vertical joint between elements

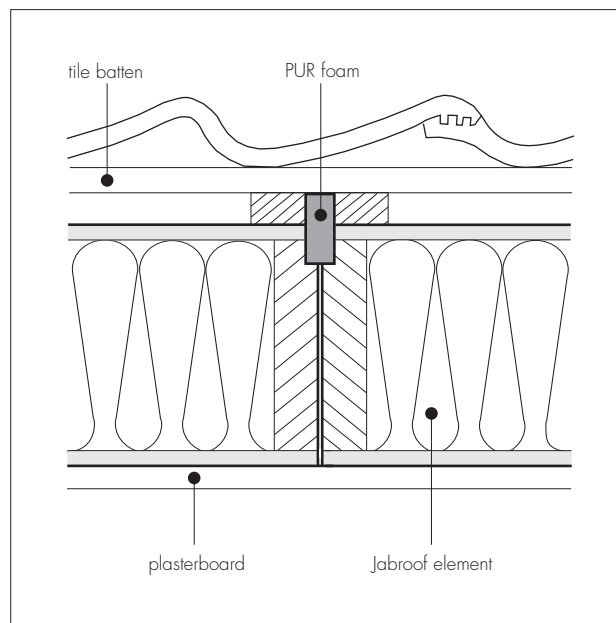

14.5 At the ridge, the elements can be bevelled to suit the pitch of the roof. The joint on the top surface is sealed with PUR foam.

14.6 Joints to the surrounding structure, eg walls, are sealed with PUR foam.

14.7 When elements are joined onto adjacent structures, the horizontal joints must be finished water-, wind- and draught-proof.

14.8 The Certificate holder supplies a self-adhesive bitumen/aluminium tape or a flashing for sealing horizontal butt joints.

14.9 The roof structure must be protected from precipitation by making the joints, recesses and ridge waterproof as soon as possible, with the roof covering applied soon afterwards.

14.10 Adequate ventilation must be provided to the roof space formed, particularly if the building operations create a more humid environment than would be expected from normal occupation.

14.11 The underside of roof projections at the eaves gables, and at open wall cavities, must be protected against dampness by such measures as painting, boarding or panelling.

14.12 Tile battens, gutter laths, tiles or slates are laid in the traditional manner to provide the final roof finish.

14.13 Plasterboard can be fixed directly to the element or on battens. The latter are used where service runs are to be incorporated.

15 Tests

15.1 Tests were carried out by SKH⁽¹⁾ to include:

- short-term behaviour
- long-term behaviour
- fire resistance
- bonding strength.

(1) SKH is a Dutch assessment authority.

15.2 Tests were carried out for the BBA to determine resistance to penetration by fire.

16 Investigations

16.1 The products were examined and assessed by SKH to determine:

- practicability of installation
- durability
- hygrothermal behaviour.

16.2 The manufacturer's installation instructions were evaluated and the installation procedures outlined and found to be practicable.

16.3 Independent examination of the manufacturing process was made on behalf of SKH, including methods adopted for quality control.

16.4 An examination was made of data on:

- structural behaviour
- hygrothermal behaviour
- durability
- fire resistance.

16.5 The load/span tables were verified by calculations against the requirements of BS EN 1995-1-1 : 2004 and the UK National Application Document by SKH.

Bibliography

BS 476-3 : 1958 *Fire tests on building materials and structures — External fire exposure roof test*

BS 5268-2 : 2002 *Structural use of timber — Code of practice for permissible stress design, materials and workmanship*

BS 5534 : 2003 *Code of practice for slating and tiling (including shingles)*

BS 6399-2 : 1997 *Loading for buildings — Code of practice for wind loads*

BS 6399-3 : 1988 *Loading for buildings — Code of practice for imposed roof loads*

BS EN 312 : 2003 *Particleboards — Specifications*

BS EN 1995-1-1 : 2004 *Eurocode 5 : Design of timber structures — General — Common rules and rules for buildings*

BS EN 10230-1 : 2000 *Steel wire nails — Loose nails for general applications*

BS EN ISO 6946 : 1997 *Building components and building elements — Thermal resistance and thermal transmittance — Calculation method*

NEN 6702 : 1991 *Technical principles for building structures — TGB 1990 — Loadings and deformations*

17 Conditions

17.1 This Certificate:

- relates only to the product/system that is named and described on the front page
- is granted only to the company, firm or person named on the front page — no other company, firm or person may hold or claim any entitlement to this Certificate
- is valid only within the UK
- has to be read, considered and used as a whole document — it may be misleading and will be incomplete to be selective
- is copyright of the BBA
- is subject to English law.

17.2 References in this Certificate to any Act of Parliament, Statutory Instrument, Directive or Regulation of the European Union, British, European or International Standard, Code of Practice, manufacturers' instructions or similar publication, are references to such publication in the form in which it was current at the date of this Certificate.

17.3 This Certificate will remain valid for an unlimited period provided that the product/system and the manufacture and/or fabrication including all related and relevant processes thereof:

- are maintained at or above the levels which have been assessed and found to be satisfactory by the BBA
- remain covered by a valid Dutch Agrément; and
- are reviewed by the BBA as and when it considers appropriate.

17.4 In granting this Certificate, the BBA is not responsible for:

- the presence or absence of any patent, intellectual property or similar rights subsisting in the product/system or any other product/system
- the right of the Certificate holder to manufacture, supply, install, maintain or market the product/system
- individual installations of the product/system, including the nature, design, methods and workmanship of or related to the installation
- the actual works in which the product/system is installed, used and maintained, including the nature, design, methods and workmanship of such works.

17.5 Any information relating to the manufacture, supply, installation, use and maintenance of this product/system which is contained or referred to in this Certificate is the minimum required to be met when the product/system is manufactured, supplied, installed, used and maintained. It does not purport in any way to restate the requirements of the Health & Safety at Work etc Act 1974, or of any other statutory, common law or other duty which may exist at the date of this Certificate; nor is conformity with such information to be taken as satisfying the requirements of the 1974 Act or of any statutory, common law or other duty of care. In granting this Certificate, the BBA does not accept responsibility to any person or body for any loss or damage, including personal injury, arising as a direct or indirect result of the manufacture, supply, installation, use and maintenance of this product/system.

Blank page

